

## Description

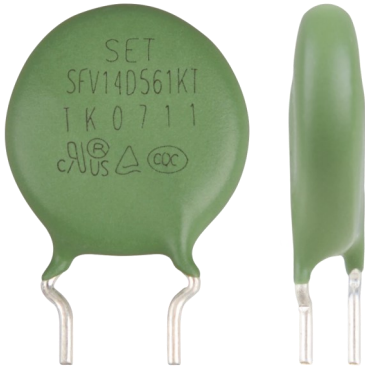

Metal Oxide Varistor (MOV) is a nonlinear resistance component with zinc oxide (ZnO) as its main constituent. The resistance of an MOV is sensitive to changes in the applied voltage. Below the threshold voltage, the MOV exhibits high resistance, allowing only a negligibly small leakage current to flow. Once the threshold voltage is exceeded, the resistance of the MOV drops sharply, enabling the conduction of a large current. This characteristic makes the MOV suitable for detecting and suppressing surge voltage and overvoltage, thereby protecting the circuit from damage caused by excessive voltage.

The Metal Oxide Varistor (MOV) finds wide application in various fields such as photovoltaics, communication, lightning protection, power supply, and power strips. It serves to suppress transient overvoltage and absorb surge energy within the circuit.

SETsafe | SETfuse offers Metal Oxide Varistors (MOV) with maximum peak current ratings ranging from 0.75 kA to 70 kA, and maximum continuous voltage ratings from 14VAC to 750 VAC. Safety certification includes UL, cUL, TUV, and CQC, and complies with RoHS and REACH requirements.

## Product Structure

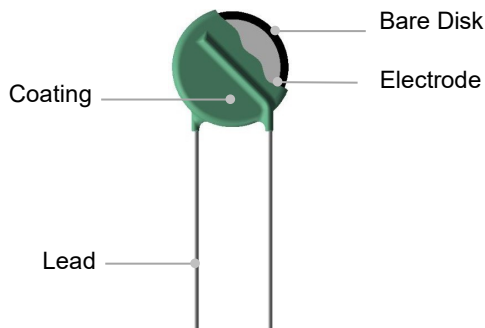

## Lead Types

Lead Types		Codes
Straight Lead		A
Outward Crimp Lead		C
Inline Crimp Lead		I
Little Straight Lead		D

## Agency Information

Agency	Standards	No.
	UL 1449 4 <sup>th</sup> Edition	E322662
	CSA C22.2 NO.269.5-17	E322662
	EN IEC 61051-1:2018 EN IEC 61051-2:2021 IEC 61051-2-2:1991 Annex G.8.1 of IEC 62368-1:2018	J 50234703
	GB/T 10193-1997 GB/T 10194-1997 GB 4943.1-2022 IEC 61051-2:1991+Amd1:2009	CQC16001152394

## Applications

- Power Supplies
- Home Electrical Appliances
- Industrial Devices
- Surge Protectors
- Telecom Devices

## Marking

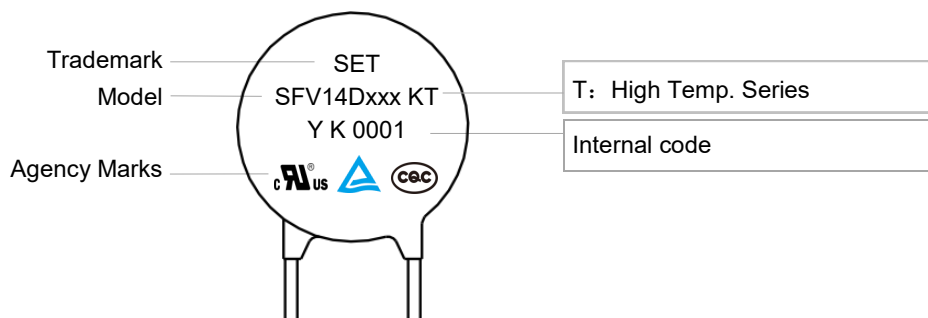

## Temp. Derating Curve

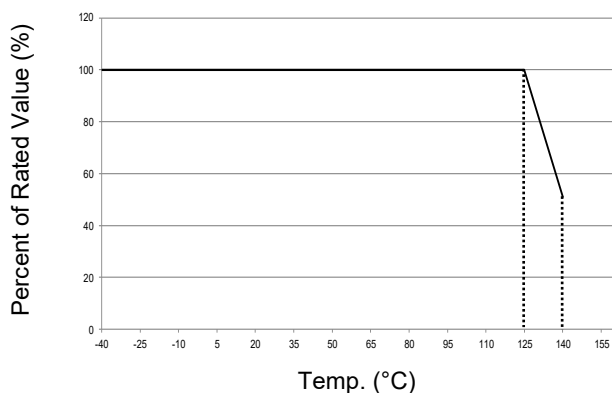

**Note:**

For high temp. series, when ambient temp. exceeds 125 °C, the peak surge current and energy rating should be reduced as shown in the left curve.

For High Temp. Series Products

## General Technical Data

Item	Value	Unit
Operating Temperature	-40 to +125	°C
Storage Temperature	-40 to +150	°C
Voltage Proof	≥2500	V <sub>ac</sub>
Insulation Resistance	≥100	MΩ

**Dimensions (mm)**

Model	L (Min.)	H (Max.)	T (Max.)	D (Max.)	d	F	F <sub>1</sub>	A (Max.)
SFV14D220KT	7	18.5	4.9	16.5	0.80±0.05	7.5±0.5	1.1 ~ 2.5	21.5
SFV14D270KT	7	18.5	5.2	16.5	0.80±0.05	7.5±0.5	1.2 ~ 2.7	21.5
SFV14D330KT	7	18.5	5.5	16.5	0.80±0.05	7.5±0.5	1.3 ~ 2.9	21.5
SFV14D390KT	7	18.5	5.8	16.5	0.80±0.05	7.5±0.5	1.4 ~ 3.1	21.5
SFV14D470KT	7	18.5	5.0	16.5	0.80±0.05	7.5±0.5	1.2 ~ 2.7	21.5
SFV14D560KT	7	18.5	5.2	16.5	0.80±0.05	7.5±0.5	1.3 ~ 2.9	21.5
SFV14D680KT	7	18.5	5.5	16.5	0.80±0.05	7.5±0.5	1.5 ~ 3.2	21.5
SFV14D820KT	7	18.5	4.8	16.5	0.80±0.05	7.5±0.5	1.2 ~ 2.6	21.5
SFV14D101KT	7	18.5	5.0	16.5	0.80±0.05	7.5±0.5	1.3 ~ 2.8	21.5
SFV14D121KT	7	18.5	5.2	16.5	0.80±0.05	7.5±0.5	1.4 ~ 3.0	21.5
SFV14D151KT	7	18.5	5.5	16.5	0.80±0.05	7.5±0.5	1.6 ~ 3.3	21.5
SFV14D181KT	7	18.5	4.9	16.5	0.80±0.05	7.5±0.5	1.0 ~ 2.6	21.5
SFV14D201KT	7	18.5	5.0	16.5	0.80±0.05	7.5±0.5	1.1 ~ 2.7	21.5
SFV14D221KT	7	18.5	5.1	16.5	0.80±0.05	7.5±0.5	1.2 ~ 2.8	21.5
SFV14D241KT	7	18.5	5.3	16.5	0.80±0.05	7.5±0.5	1.3 ~ 2.9	21.5
SFV14D271KT	7	18.5	5.4	16.5	0.80±0.05	7.5±0.5	1.4 ~ 3.1	21.5
SFV14D301KT	7	18.5	5.6	16.5	0.80±0.05	7.5±0.5	1.5 ~ 3.2	21.5
SFV14D331KT	7	18.5	5.8	16.5	0.80±0.05	7.5±0.5	1.6 ~ 3.3	21.5
SFV14D361KT	7	18.5	6.0	16.5	0.80±0.05	7.5±0.5	1.7 ~ 3.5	21.5
SFV14D391KT	7	18.5	6.1	16.5	0.80±0.05	7.5±0.5	1.8 ~ 3.6	21.5
SFV14D431KT	7	18.5	6.4	16.5	0.80±0.05	7.5±0.5	1.8 ~ 3.8	21.5
SFV14D471KT	7	18.5	6.6	16.5	0.80±0.05	7.5±0.5	2.0 ~ 4.0	21.5
SFV14D511KT	7	18.5	6.8	16.5	0.80±0.05	7.5±0.5	2.2 ~ 4.2	21.5
SFV14D561KT	7	18.5	7.1	16.5	0.80±0.05	7.5±0.5	2.4 ~ 4.4	21.5
SFV14D621KT	7	18.5	7.5	16.5	0.80±0.05	7.5±0.5	2.7 ~ 4.7	21.5
SFV14D681KT	7	18.5	7.8	16.5	0.80±0.05	7.5±0.5	3.0 ~ 5.0	21.5
SFV14D751KT	7	18.5	8.3	16.5	0.80±0.05	7.5±0.5	3.3 ~ 5.3	21.5
SFV14D821KT	7	18.5	8.7	16.5	0.80±0.05	7.5±0.5	3.6 ~ 5.6	21.5
SFV14D911KT	7	18.5	9.2	16.5	0.80±0.05	7.5±0.5	4.0 ~ 6.0	21.5
SFV14D102KT	7	18.5	9.7	16.5	0.80±0.05	7.5±0.5	4.5 ~ 6.5	21.5
SFV14D112KT	7	18.5	10.3	16.5	0.80±0.05	7.5±0.5	4.9 ~ 6.9	21.5
SFV14D122KT	7	18.5	10.9	16.5	0.80±0.05	7.5±0.5	5.4 ~ 7.4	21.5

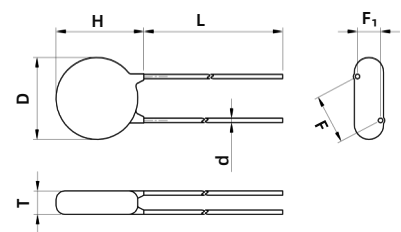

Straight Lead (A)

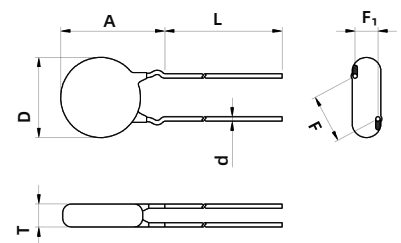

Outward Crimp (C)

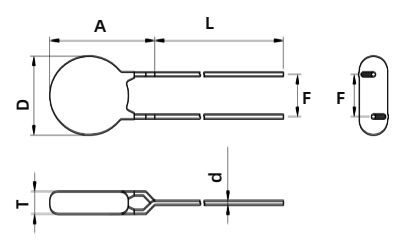

Inline Crimp (D)

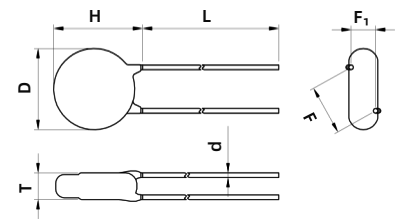

Little Straight Lead (I)

**Note:**

The above data is for reference only.

### Part Numbering System

SFV 14 D 471 - K T K A BUL - 001

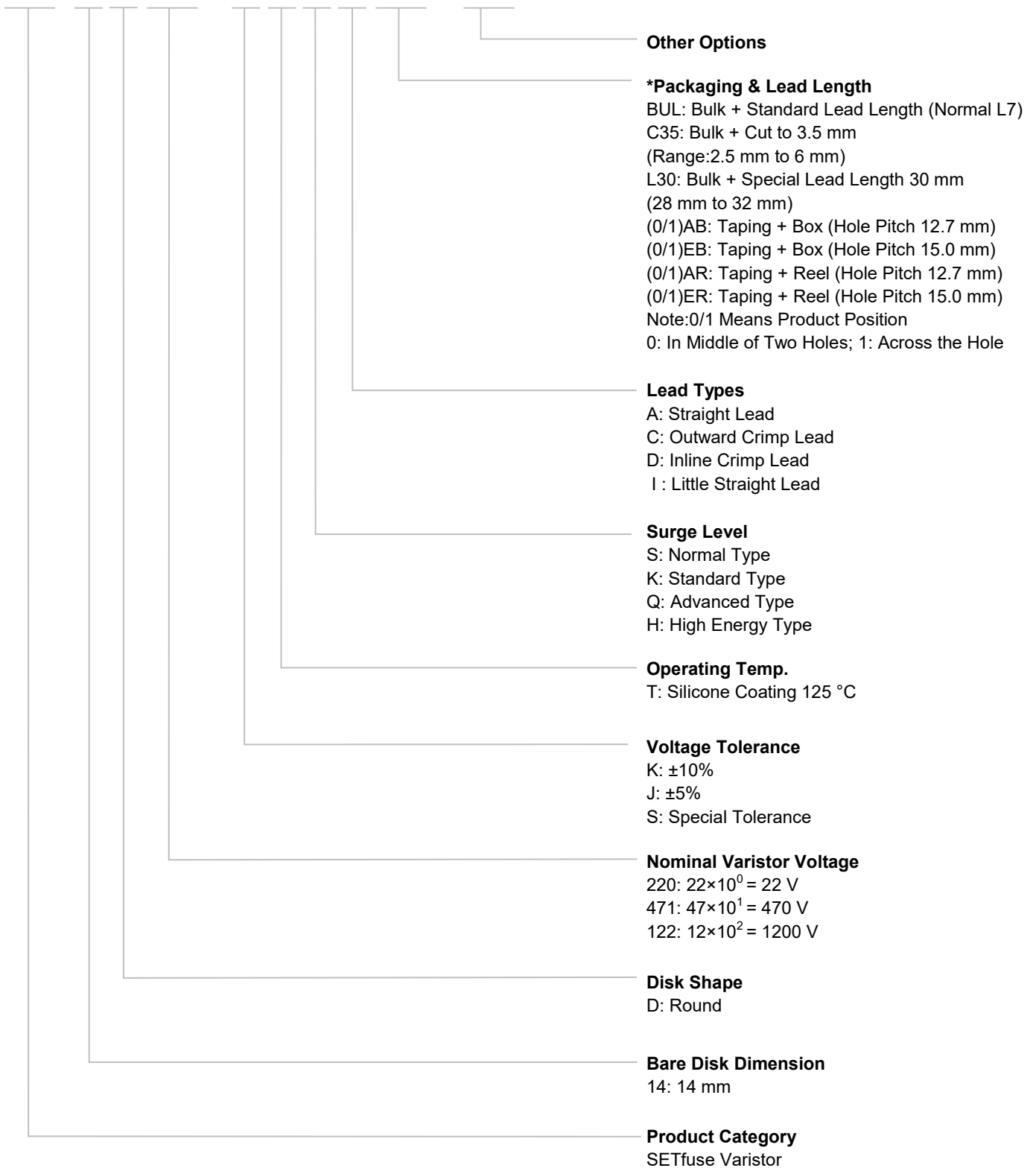

**Reminder:**

Part numbering system in the datasheet is only for selecting correct parameter and product features. Before placing order, please contact us for specifications and use the part number and product code in the specifications to place order to ensure the part is correct. Product code is the unique identification.

**Specification**

Model	Surge Level	Max. Continuous Operating Voltage		Varistor Voltage @1 mA DC		Clamping Voltage (Max.)		Max. Peak Current (1 time, 8/20 μs)	Max. Energy (10/1000 μs)	Typical Capacitance (For reference only) @1 kHz	Agency Information					
		VAC	VDC	Min.	Max.	V <sub>C</sub>	I <sub>P</sub>				S		UL	cUL	TUV	CQC
		(V)	(V)	(V)	(V)	(V)	(A)				(kA)	(J)				
SFV14D220KT	S	14	18	20	24	43	10	1	5.0	9100	○	○	●	●		
SFV14D270KT	S	17	22	24	31	53	10	1	6.0	7400	○	○	●	●		
SFV14D330KT	S	20	26	30	36	65	10	1	7.5	6100	○	○	●	●		
SFV14D390KT	S	25	31	35	43	77	10	1	8.6	5100	○	○	●	●		
SFV14D470KT	S	30	38	42	52	93	10	1	10	4300	○	○	●	●		
SFV14D560KT	S	35	45	50	62	110	10	1	11	3600	○	○	●	●		
SFV14D680KT	S	40	56	61	75	135	10	1	14	2900	○	○	●	●		
SFV14D820KT	S	50	65	74	90	135	50	4.5	22	2400	●	●	●	●		
SFV14D101KT	S	60	85	90	110	165	50	4.5	28	2000	●	●	●	●		
SFV14D121KT	S	75	100	108	132	200	50	4.5	32	1700	●	●	●	●		
SFV14D151KT	S	95	125	135	165	250	50	4.5	40	1300	●	●	●	●		
SFV14D181KT	S	115	150	162	198	300	50	4.5	50	1100	●	●	●	●		
SFV14D201KT	S	130	170	180	220	340	50	4.5	57	1000	●	●	●	●		
SFV14D221KT	S	140	180	198	242	360	50	4.5	60	900	●	●	●	●		
SFV14D241KT	S	150	200	216	264	395	50	4.5	63	830	●	●	●	●		
SFV14D271KT	S	175	225	243	297	455	50	4.5	70	740	●	●	●	●		
SFV14D301KT	S	190	250	270	330	500	50	4.5	77	670	●	●	●	●		
SFV14D331KT	S	210	275	297	363	550	50	4.5	85	610	●	●	●	●		
SFV14D361KT	S	230	300	324	396	595	50	4.5	93	560	●	●	●	●		
SFV14D391KT	S	250	320	351	429	650	50	4.5	100	510	●	●	●	●		
SFV14D431KT	S	275	350	387	473	710	50	4.5	115	460	●	●	●	●		
SFV14D471KT	S	300	385	423	517	775	50	4.5	125	430	●	●	●	●		
SFV14D511KT	S	320	415	459	561	845	50	4.5	125	390	●	●	●	●		
SFV14D561KT	S	350	460	504	616	925	50	4.5	125	360	●	●	●	●		
SFV14D621KT	S	385	505	558	682	1025	50	4.5	125	320	●	●	●	●		
SFV14D681KT	S	420	560	612	748	1120	50	4.5	130	290	●	●	●	●		
SFV14D751KT	S	460	615	675	825	1240	50	4.5	143	270	●	●	●	●		
SFV14D821KT	S	510	670	738	902	1355	50	4.5	157	240	●	●	●	●		
SFV14D911KT	S	550	745	819	1001	1500	50	4.5	175	220	●	●	●	●		
SFV14D102KT	S	625	825	900	1100	1650	50	4.5	190	200	●	●	●	●		
SFV14D112KT	S	680	895	990	1210	1815	50	4.5	213	180	●	●	●	●		
SFV14D122KT	S	750	990	1080	1320	1980	50	4.5	213	150	●	●	●	●		





● : Approved      ○ : Unauthorized      ● : RoHS & REACH Compliant

**Specification**

Model	Surge Level	Max. Continuous Operating Voltage		Varistor Voltage @1 mA DC		Clamping Voltage (Max.)		Max. Peak Current (1 time, 8/20 μs)	Max. Energy (10/1000 μs)	Typical Capacitance (For reference only) @1 kHz	Agency Information			
		VAC	VDC	Min.	Max.	V <sub>C</sub>	I <sub>P</sub>				K		(pF)	UL
		(V)	(V)	(V)	(V)	(V)	(A)	(kA)	(J)					
SFV14D220K	K	14	18	20	24	43	10	2	6.3	9100	○	○	●	●
SFV14D270KT	K	17	22	24	31	53	10	2	7.8	7400	○	○	●	●
SFV14D330KT	K	20	26	30	36	65	10	2	9.5	6100	○	○	●	●
SFV14D390KT	K	25	31	35	43	77	10	2	11	5100	○	○	●	●
SFV14D470KT	K	30	38	42	52	93	10	2	14	4300	○	○	●	●
SFV14D560KT	K	35	45	50	62	110	10	2	16	3600	○	○	●	●
SFV14D680KT	K	40	56	61	75	135	10	2	20	2900	○	○	●	●
SFV14D820KT	K	50	65	74	90	135	50	6	28	2400	●	●	●	●
SFV14D101KT	K	60	85	90	110	165	50	6	35	2000	●	●	●	●
SFV14D121KT	K	75	100	108	132	200	50	6	42	1700	●	●	●	●
SFV14D151KT	K	95	125	135	165	250	50	6	53	1300	●	●	●	●
SFV14D181KT	K	115	150	162	198	300	50	6	60	1100	●	●	●	●
SFV14D201KT	K	130	170	180	220	340	50	6	70	1000	●	●	●	●
SFV14D221KT	K	140	180	198	242	360	50	6	78	900	●	●	●	●
SFV14D241KT	K	150	200	216	264	395	50	6	84	830	●	●	●	●
SFV14D271KT	K	175	225	243	297	455	50	6	99	740	●	●	●	●
SFV14D301KT	K	190	250	270	330	500	50	6	108	670	●	●	●	●
SFV14D331KT	K	210	275	297	363	550	50	6	115	610	●	●	●	●
SFV14D361KT	K	230	300	324	396	595	50	6	130	560	●	●	●	●
SFV14D391KT	K	250	320	351	429	650	50	6	140	510	●	●	●	●
SFV14D431KT	K	275	350	387	473	710	50	6	155	460	●	●	●	●
SFV14D471KT	K	300	385	423	517	775	50	6	175	430	●	●	●	●
SFV14D511KT	K	320	415	459	561	845	50	6	180	390	●	●	●	●
SFV14D561KT	K	350	460	504	616	925	50	6	185	360	●	●	●	●
SFV14D621KT	K	385	505	558	682	1025	50	6	190	320	●	●	●	●
SFV14D681KT	K	420	560	612	748	1120	50	6	200	290	●	●	●	●
SFV14D751KT	K	460	615	675	825	1240	50	6	210	270	●	●	●	●
SFV14D821KT	K	510	670	738	902	1355	50	6	235	240	●	●	●	●
SFV14D911KT	K	550	745	819	1001	1500	50	6	255	220	●	●	●	●
SFV14D102KT	K	625	825	900	1100	1650	50	6	270	200	●	●	●	●
SFV14D112KT	K	680	895	990	1210	1815	50	6	280	180	●	●	●	●
SFV14D122KT	K	750	990	1080	1320	1980	50	6	310	150	●	●	●	●

●: Approved      ○: Unauthorized      ●: RoHS & REACH Compliant

**Specification**

Model	Surge Level	Max. Continuous Operating Voltage		Varistor Voltage @1 mA DC		Clamping Voltage (Max.)		Max. Peak Current (1 time, 8/20 μs)	Max. Energy (8/20 μs)	Typical Capacitance (For reference only) @1 kHz	Agency Information						
		VAC	VDC	Min.	Max.	V <sub>C</sub>	I <sub>P</sub>				H		(pF)				
		(V)	(V)	(V)	(V)	(V)	(A)				(kA)	(J)		UL	cUL	TUV	CQC
SFV14D201KT	H	130	170	180	220	340	50	8	150	1000	●	●	●	●			
SFV14D221KT	H	140	180	198	242	360	50	8	160	900	●	●	●	●			
SFV14D241KT	H	150	200	216	264	395	50	8	180	830	●	●	●	●			
SFV14D271KT	H	175	225	243	297	455	50	8	200	740	●	●	●	●			
SFV14D301KT	H	190	250	270	330	500	50	8	220	670	●	●	●	●			
SFV14D331KT	H	210	275	297	363	550	50	8	245	610	●	●	●	●			
SFV14D361KT	H	230	300	324	396	595	50	8	260	560	●	●	●	●			
SFV14D391KT	H	250	320	351	429	650	50	8	290	510	●	●	●	●			
SFV14D431KT	H	275	350	387	473	710	50	8	320	460	●	●	●	●			
SFV14D471KT	H	300	385	423	517	775	50	8	350	430	●	●	●	●			
SFV14D511KT	H	320	415	459	561	845	50	8	380	390	●	●	●	●			
SFV14D561KT	H	350	460	504	616	925	50	8	400	360	●	●	●	●			
SFV14D621KT	H	385	505	558	682	1025	50	8	400	320	●	●	●	●			
SFV14D681KT	H	420	560	612	748	1120	50	8	400	290	●	●	●	●			

●: Approved      ○: Unauthorized      ●: RoHS & REACH Compliant

**Specification**

Model	Surge Level	Max. Continuous Operating Voltage		Varistor Voltage @1 mA DC		Clamping Voltage (Max.)		Pulse Impact Performance (40 times) (1.2/50 μs & 8/20 μs)	Max. Energy (10/1000 μs)	Typical Capacitance (For reference only) @1 kHz	Agency Information						
		VAC	VDC	Min.	Max.	V <sub>C</sub>	I <sub>P</sub>				Q		(pF)	UL	cUL	TUV	CQC
		(V)	(V)	(V)	(V)	(V)	(A)				(kV)	(J)		UL	cUL	TUV	CQC
SFV14D201KT	Q	130	170	180	220	340	50	6.6	70	1000	●	●	●	●			
SFV14D221KT	Q	140	180	198	242	360	50	6.6	78	900	●	●	●	●			
SFV14D241KT	Q	150	200	216	264	395	50	6.6	84	830	●	●	●	●			
SFV14D271KT	Q	175	225	243	297	455	50	6.6	99	740	●	●	●	●			
SFV14D301KT	Q	190	250	270	330	500	50	6.6	108	670	●	●	●	●			
SFV14D331KT	Q	210	275	297	363	550	50	6.6	115	610	●	●	●	●			
SFV14D361KT	Q	230	300	324	396	595	50	6.6	130	560	●	●	●	●			
SFV14D391KT	Q	250	320	351	429	650	50	6.6	140	510	●	●	●	●			
SFV14D431KT	Q	275	350	387	473	710	50	6.6	155	460	●	●	●	●			
SFV14D471KT	Q	300	385	423	517	775	50	6.6	175	430	●	●	●	●			
SFV14D511KT	Q	320	415	459	561	845	50	6.6	180	390	●	●	●	●			
SFV14D561KT	Q	350	460	504	616	925	50	6.6	185	360	●	●	●	●			
SFV14D621KT	Q	385	505	558	682	1025	50	6.6	190	320	●	●	●	●			
SFV14D681KT	Q	420	560	612	748	1120	50	6.6	200	290	●	●	●	●			

●: Approved      ○: Unauthorized      ●: RoHS & REACH Compliant



**Performance Curve (For reference only )**

- Max. Peak Current Derating Curves

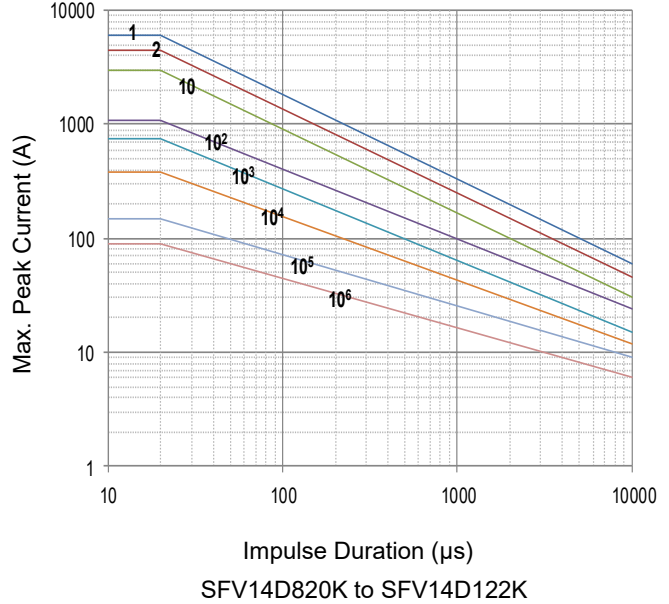
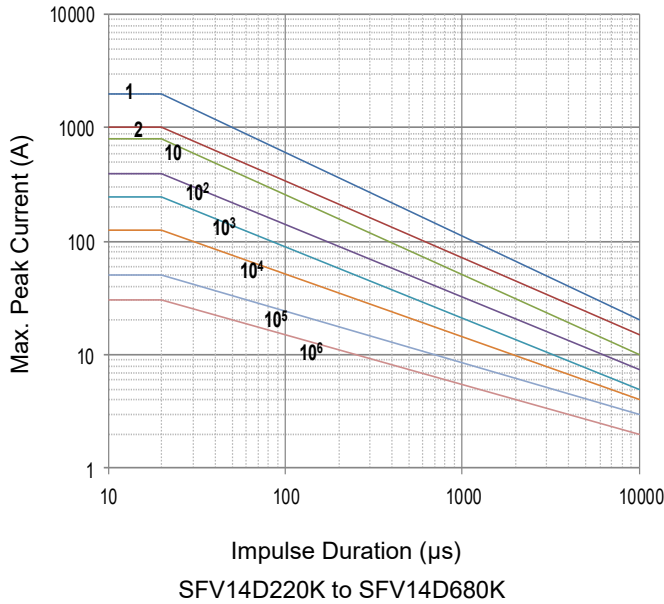

Note: 1, 2, 10,  $10^2$ ,  $10^3$ ,  $10^4$ ,  $10^5$ ,  $10^6$  Stand for Repetitions.

- Voltage-Current Characteristic Curves

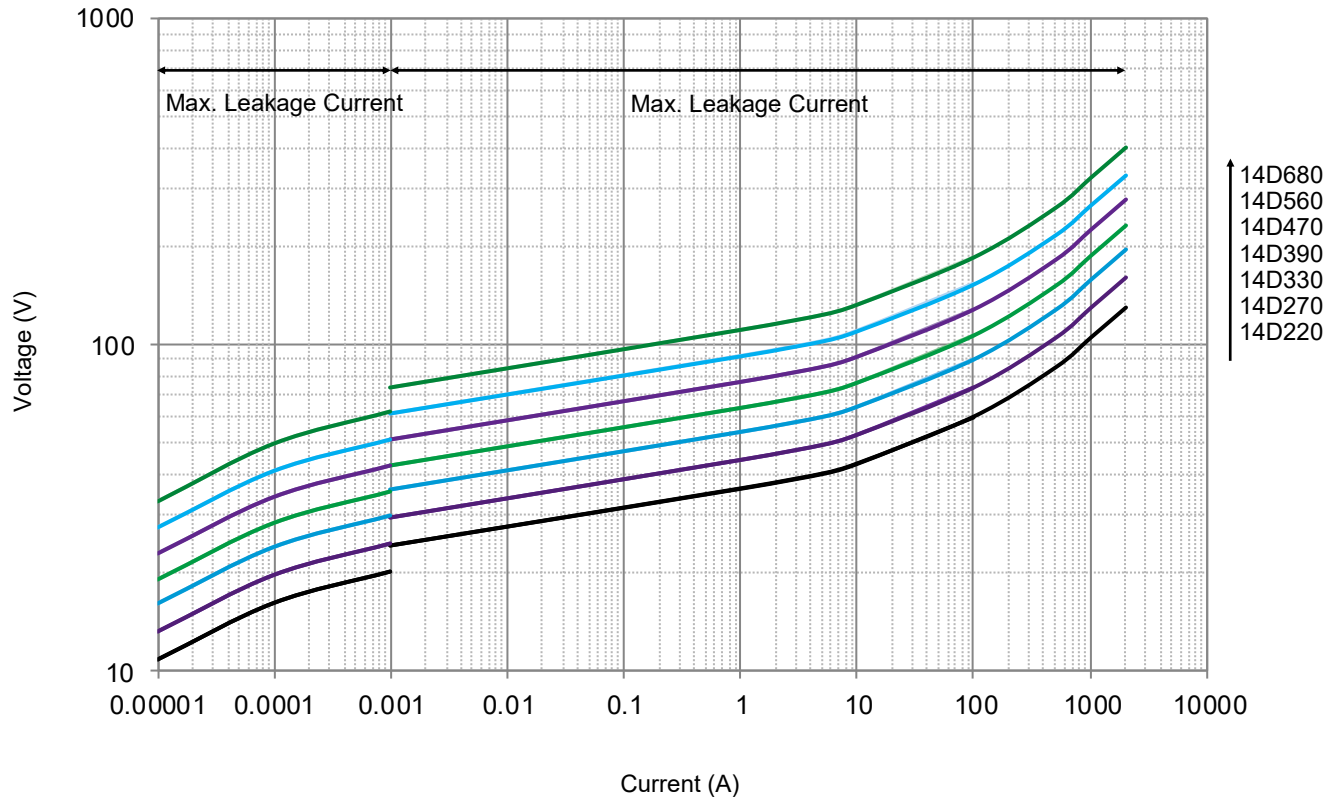

• Voltage-Current Characteristic Curves

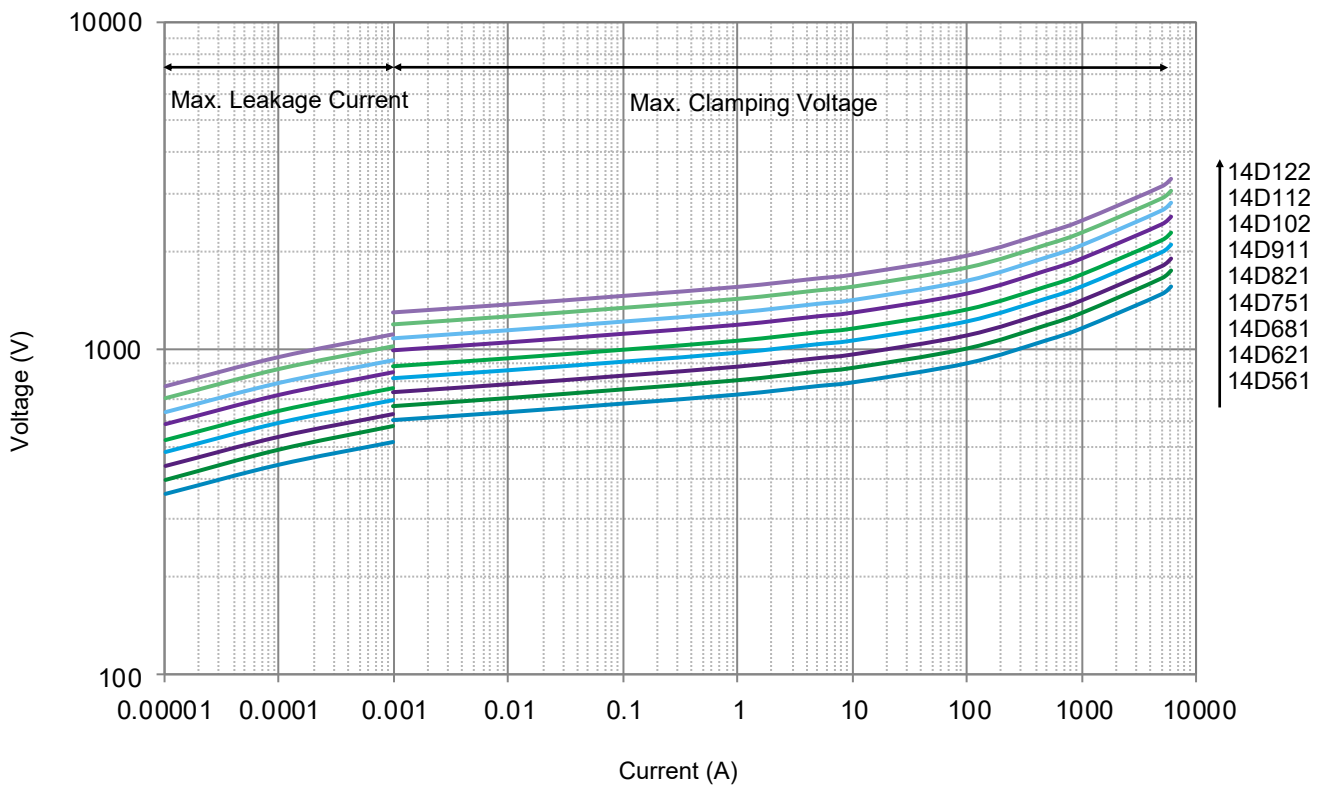
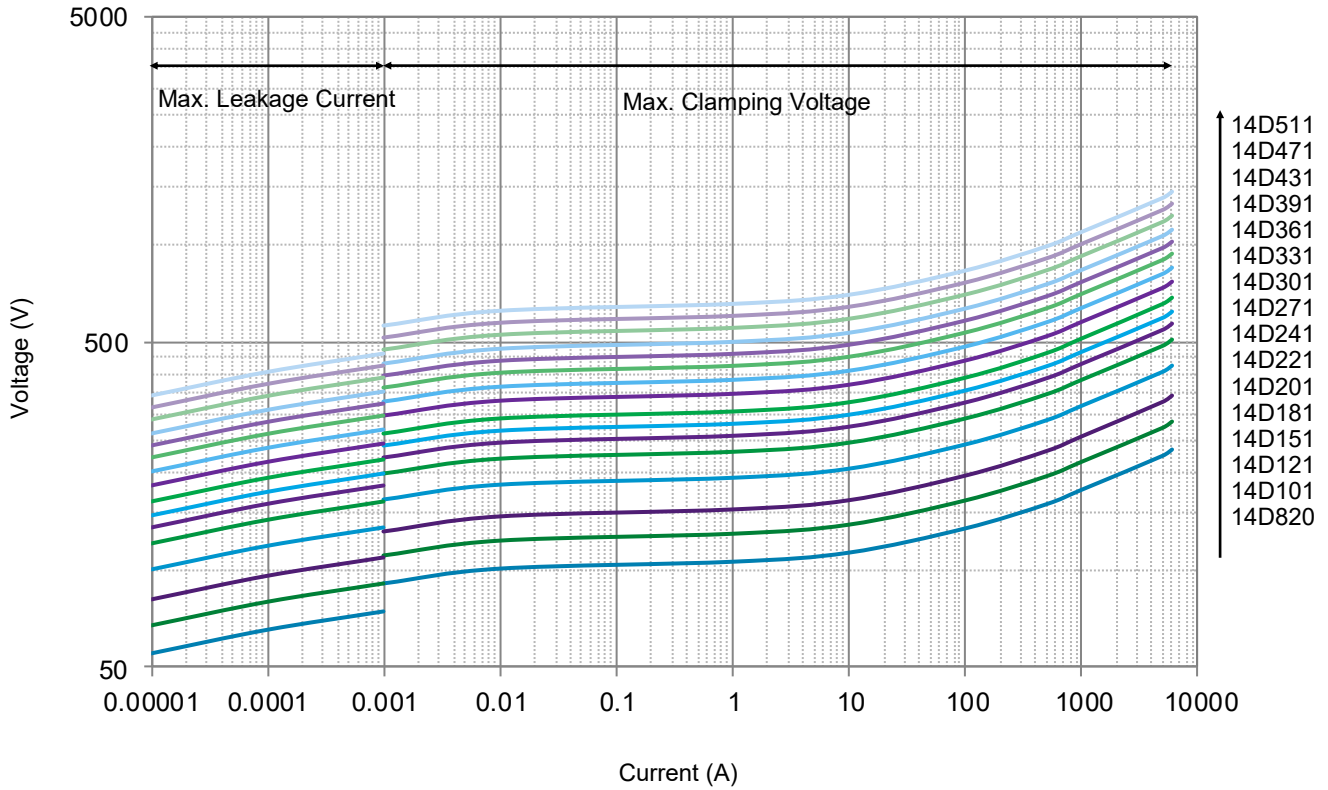

### Packaging Information

- Bulk Packaging (Code: BUL)
- Bulk Packaging Quantity & Weight.

Series	Nominal Varistor Voltage	PE Bag	Box	Carton	G. W / Carton (365 × 265 × 245)
	(V)	(PCS)	(PCS)	(PCS)	(kg)±10%
SFV14D T Series	220 ~ 361	200	400	2400	4 ~ 7
	391 ~ 621	150	300	1800	5 ~ 7
	681 ~122	100	200	1200	5 ~ 8

Note:  
Other lead length packaging information, please contact SETsafe | SETfuse.

All Dimensions in mm

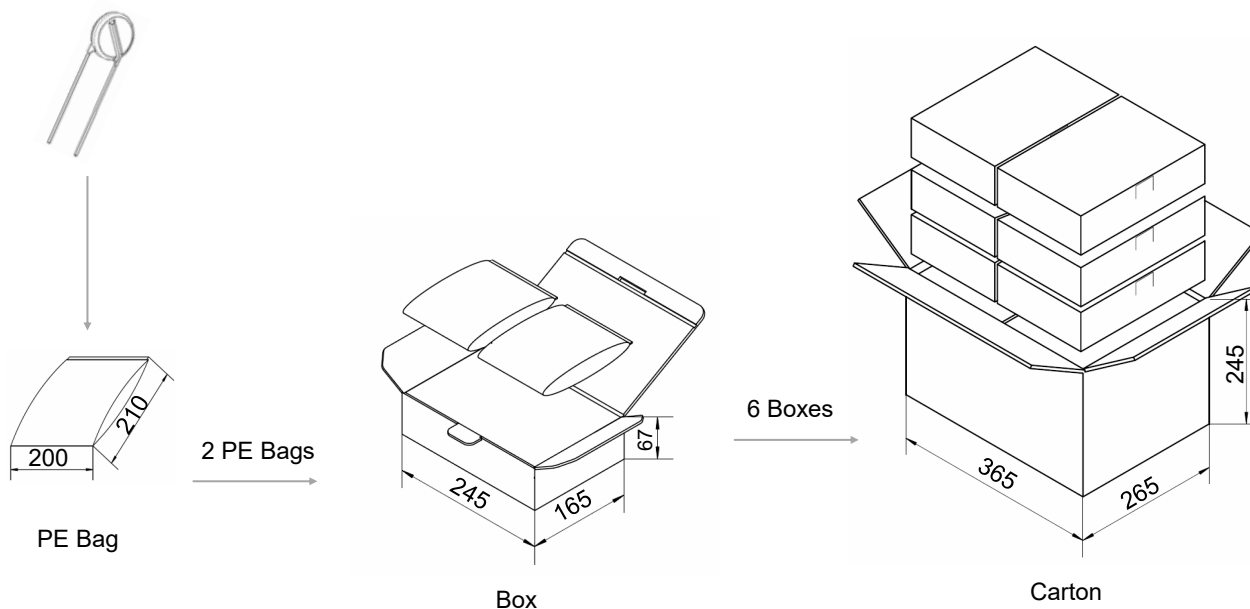

**Packaging Information**

- Tape Packaging (Code: 0AB)

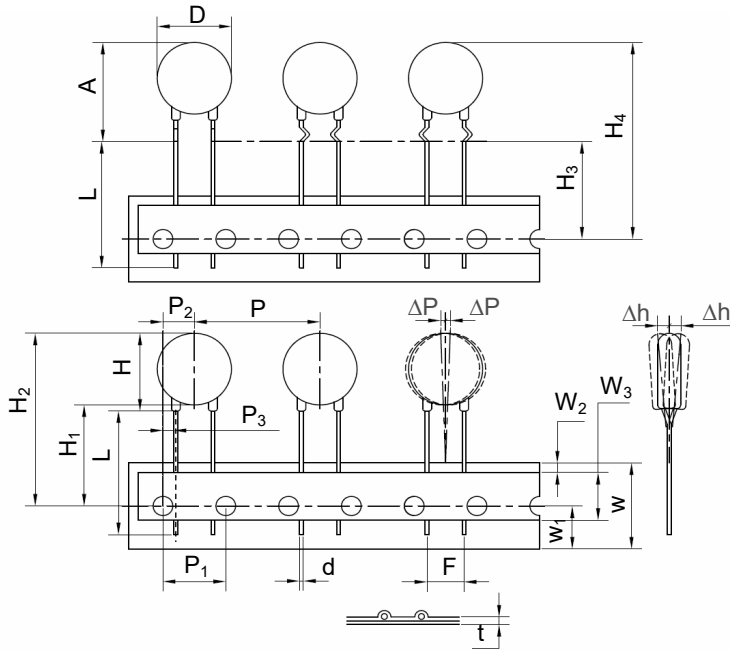

Dimensions (mm)	
P	25.4±1.0
P <sub>1</sub>	12.7±0.3
P <sub>2</sub>	6.35±1.3
P <sub>3</sub>	2.6±0.7
ΔP(max.)	1.0
W	18.0±1.0
W <sub>1</sub>	9.0±1.0
W <sub>2</sub> (max.)	3.0
W <sub>3</sub>	10.0±2.0
H(max.)	18.5
H <sub>1</sub>	18.0
H <sub>2</sub> (max.)	40.0 <sup>+2.0</sup> <sub>-0</sub>
H <sub>3</sub>	18.0
H <sub>4</sub> (max.)	42.0 <sup>+2.0</sup> <sub>-0</sub>
Δh(max.)	2.0
t(max.)	0.6
D(max.)	16.5
D <sub>0</sub>	4.0±0.2
d	0.80±0.05
A(max.)	21.5
F	7.5±0.5
L(min.)	Taping

- Tape Packaging Quantity & Weight.

Series	Nominal Varistor Voltage	Box	Carton	G. W / Carton (365 × 265 × 415)
	(V)	(PCS)	(PCS)	(kg)±10%
14D	112 ~ 122	250	1750	11 ~ 12
	681 ~ 102	300	2100	9 ~ 12
	471 ~ 621	400	2800	9 ~ 11
	301 ~ 431	500	3500	8 ~ 11
	680			8
	390 ~ 560	600	4200	8 ~ 10
	820 ~ 271			7 ~ 9
	220 ~ 330	700	4900	7 ~ 9

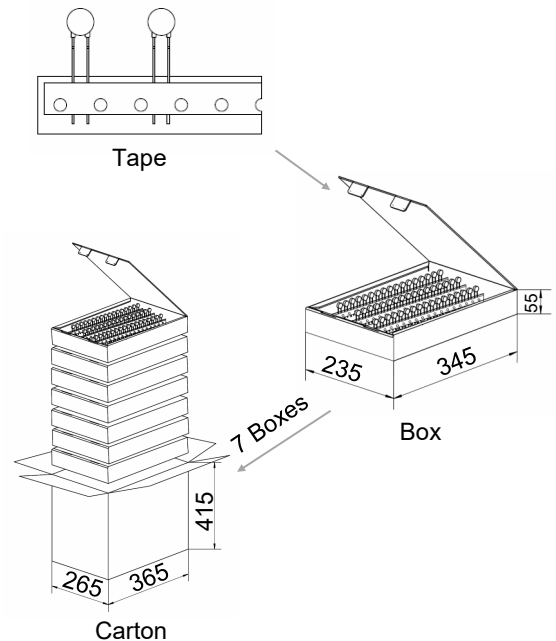

### Packaging Information

- Tape Packaging (Code: 1AB)

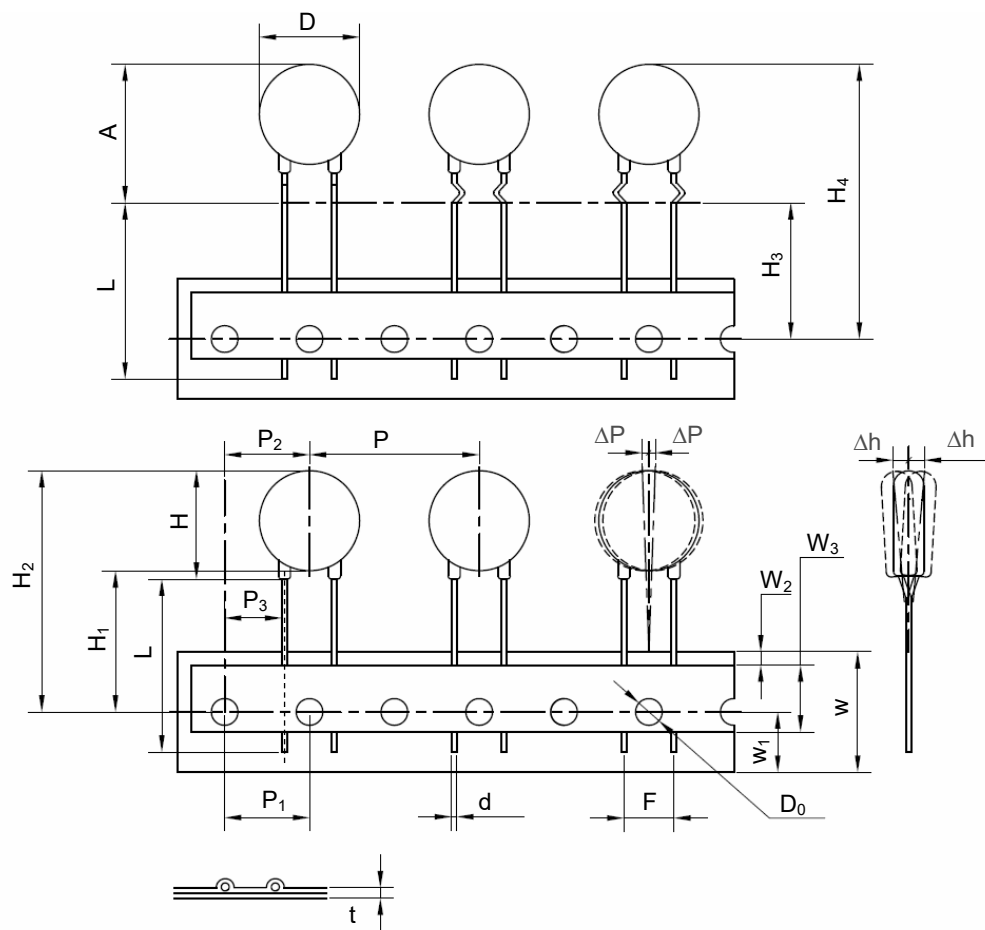

Dimensions (mm)	
P	25.4±1.0
P <sub>1</sub>	12.7±0.3
P <sub>2</sub>	12.7±1.3
P <sub>3</sub>	8.95±0.7
ΔP(max.)	1.0
W	18.0±1.0
W <sub>1</sub>	9.0±1.0
W <sub>2</sub> (max.)	3.0
W <sub>3</sub>	10.0±2.0
H(max.)	18.5
H <sub>1</sub>	18.0
H <sub>2</sub> (max.)	40.0 <sup>+2.0</sup> <sub>-0</sub>
H <sub>3</sub>	18.0
H <sub>4</sub> (max.)	42.0 <sup>+2.0</sup> <sub>-0</sub>
Δh(max.)	2.0
t (max.)	0.6
D(max.)	16.5
D <sub>0</sub>	4.0±0.2
d	0.80±0.05
A(max.)	21.5
F	7.5±0.5
L(min.)	Taping

- Tape Packaging Quantity & Weight.

Series	Nominal Varistor Voltage (V)	Box (PCS)	Carton (PCS)	G. W / Carton (365 × 265 × 415) (kg)±10%
14D	112 ~ 122	250	1750	10 ~ 12
	681 ~ 102	300	2100	9 ~ 12
	471 ~ 621	400	2800	9 ~ 11
	301 ~ 431	500	3500	8 ~ 10
	680			9
	390 ~ 560	600	4200	7 ~ 9
	820 ~ 271			6 ~ 9
	220 ~ 330	700	4900	6 ~ 8

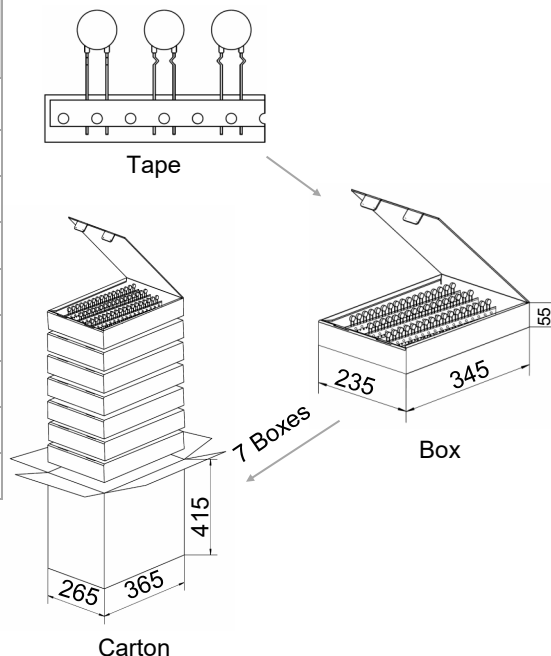

### Packaging Information

- Tape Packaging (Code: 0EB)

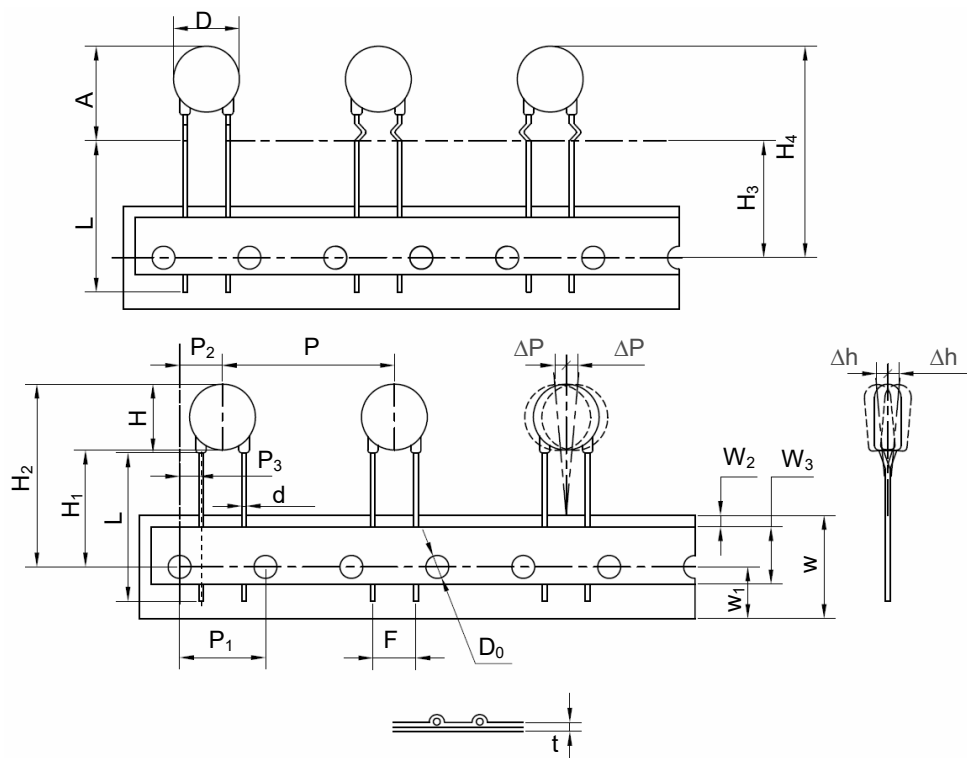

Dimensions (mm)	
P	30.0±1.0
P <sub>1</sub>	15.0±0.3
P <sub>2</sub>	7.5±1.3
P <sub>3</sub>	3.75±0.7
ΔP(max.)	1.0
W	18.0±1.0
W <sub>1</sub>	9.0±1.0
W <sub>2</sub> (max.)	3.0
W <sub>3</sub>	10.0±2.0
H(max.)	18.5
H <sub>1</sub>	18.0
H <sub>2</sub> (max.)	40.0 <sup>+2.0</sup> <sub>-0</sub>
H <sub>3</sub>	18.0
H <sub>4</sub> (max.)	42.0 <sup>+2.0</sup> <sub>-0</sub>
Δh(max.)	2.0
t (max.)	0.6
D(max.)	16.5
D <sub>0</sub>	4.0±0.2
d	0.80±0.05
A(max.)	21.5
F	7.5±0.5
L(min.)	Taping

- Tape Packaging Quantity & Weight.

Series	Nominal Varistor Voltage	Box	Carton	G. W / Carton (365 × 265 × 415)
	(V)	(PCS)	(PCS)	(kg)±10%
14D	112 ~ 122	200	1400	8 ~ 9
	821 ~ 102	250	1750	8 ~ 9
	681 ~ 751	300	2100	8 ~ 9
	511 ~ 621	350	2450	8 ~ 9
	391 ~ 471			7 ~ 9
	301 ~ 361	450	3150	7 ~ 9
	680			9
	241 ~ 271	500	3500	6 ~ 7
	151			7
	470 ~ 560			6 ~ 8
	181 ~ 221	550	3850	6 ~ 7
	101 ~ 121			
	330 ~ 390			
	820	600	4200	6
220 ~ 270	5 ~ 6			

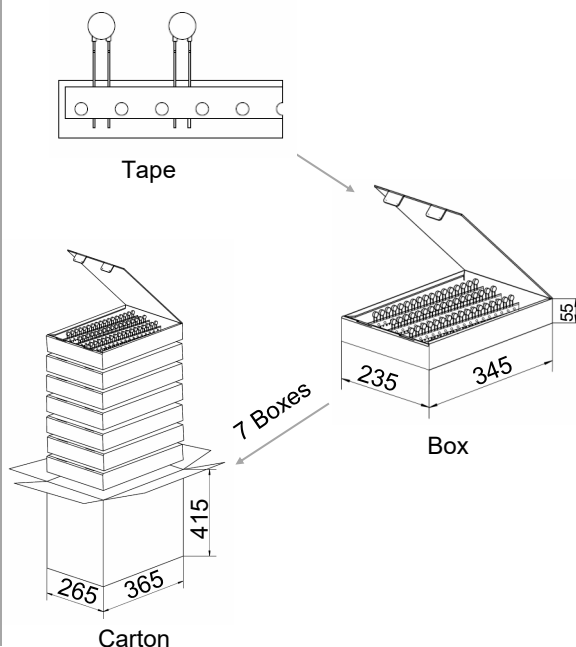

**Packaging Information**

- Tape Packaging (Code: 1EB)

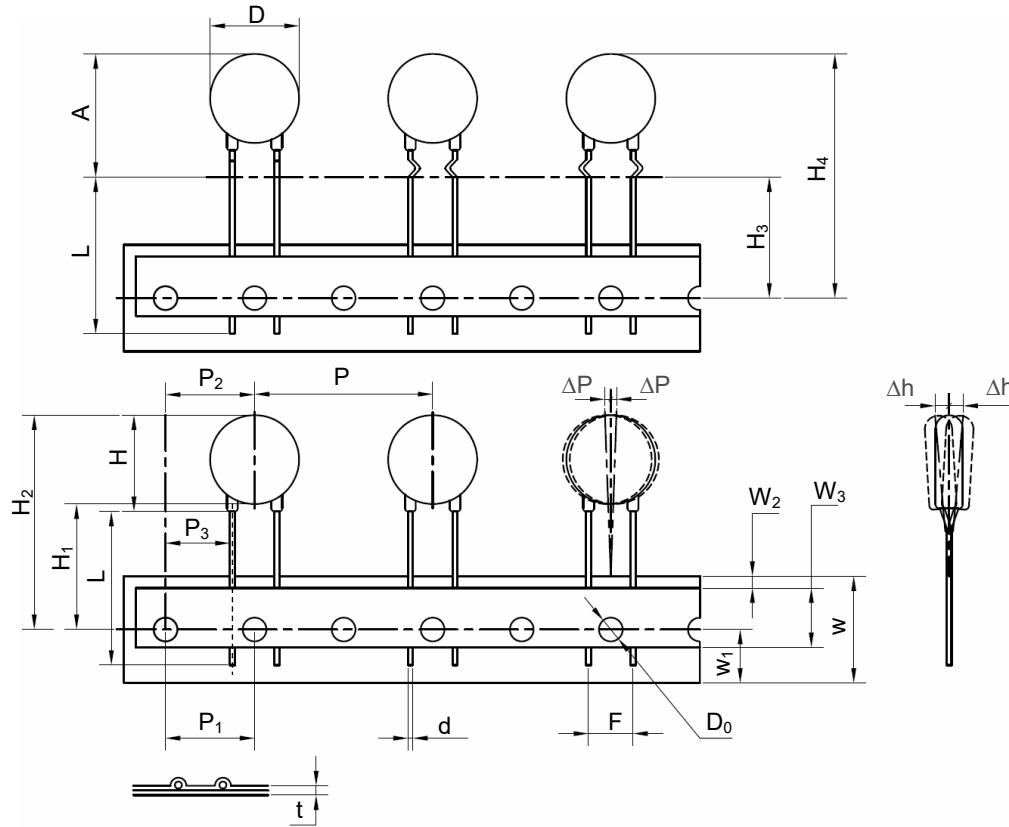

Dimensions (mm)	
P	30.0±1.0
P <sub>1</sub>	15.0±0.3
P <sub>2</sub>	15.0±1.3
P <sub>3</sub>	11.25±0.7
ΔP(max.)	1.0
W	18.0±1.0
W <sub>1</sub>	9.0±1.0
W <sub>2</sub> (max.)	3.0
W <sub>3</sub>	10.0±2.0
H(max.)	18.5
H <sub>1</sub>	18.0
H <sub>2</sub> (max.)	40.0 <sup>+2.0</sup> <sub>-0</sub>
H <sub>3</sub>	18.0
H <sub>4</sub> (max.)	42.0 <sup>+2.0</sup> <sub>-0</sub>
Δh(max.)	2.0
t(max.)	0.6
D(max.)	16.5
D <sub>0</sub>	4.0±0.2
d	0.80±0.05
A(max.)	21.5
F	7.5±0.5
L(min.)	Taping

- Tape Packaging Quantity & Weight.

Series	Nominal Varistor Voltage (V)	Box (PCS)	Carton (PCS)	G. W / Carton (365 × 265 × 415) (kg)±10%
14D	112 ~ 122	200	1400	8 ~ 9
	821 ~ 102	250	1750	8 ~ 9
	681 ~ 751	300	2100	8 ~ 9
	511 ~ 621	350	2450	8 ~ 9
	391 ~ 471			7 ~ 9
	301 ~ 361	450	3150	7 ~ 9
	680			9
	241 ~ 271	500	3500	6 ~ 7
	151			7
	470 ~ 560			6 ~ 8
	181 ~ 221	550	3850	6 ~ 7
	101 ~ 121			6 ~ 7
	330 ~ 390			6 ~ 7
	820	600	4200	6
	220 ~ 270			5 ~ 6

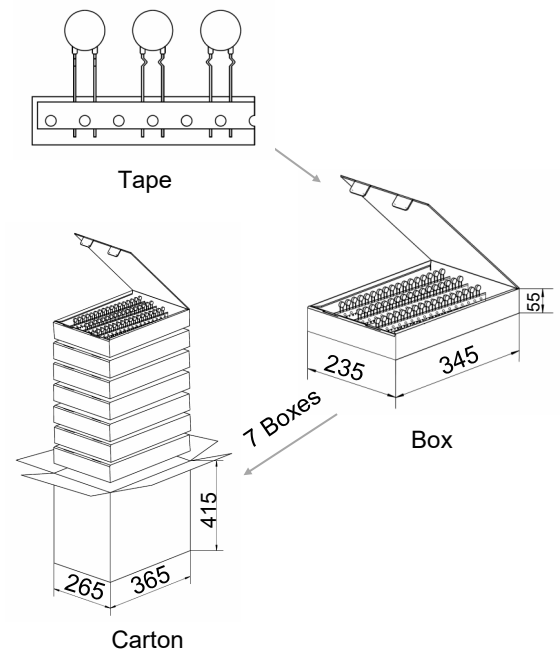





## Installation

### Mechanical Stress

Do not knock MOV when installing, to avoid mechanical damage.

## Soldering Parameters

### Wave Soldering Parameters

The wave soldering parameters are for reference only. When MOV is for practice use, some related validation is recommended.

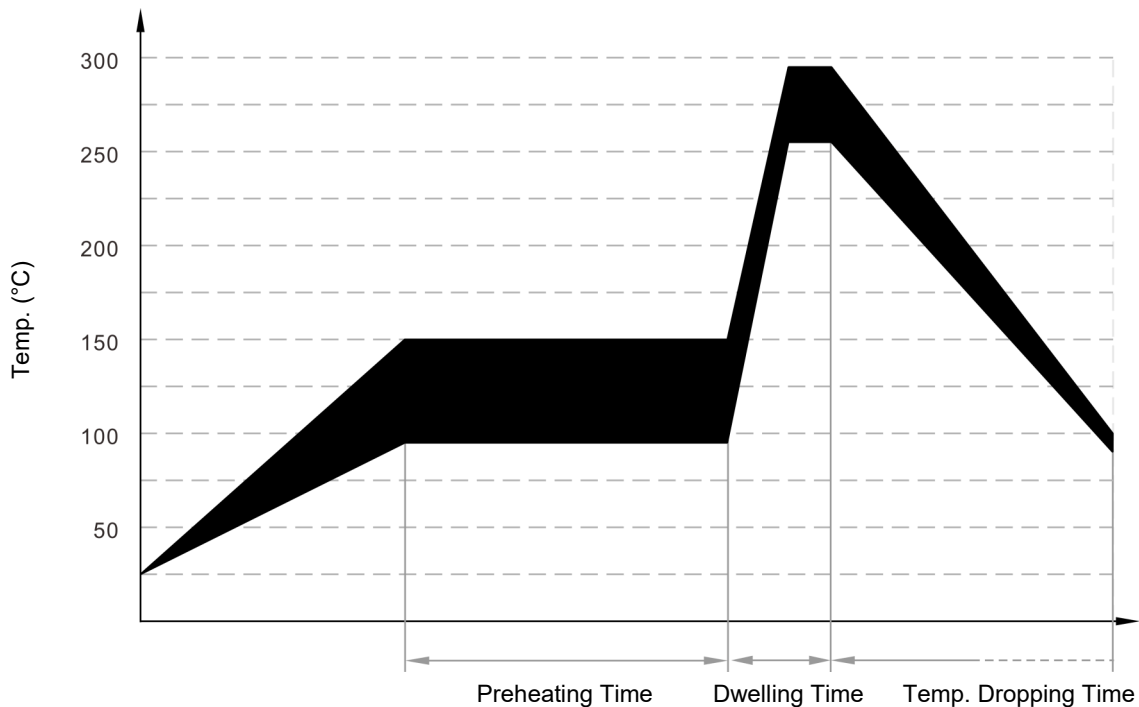

Wave Soldering Curve

Item	Temp. (°C)	Time (s)
Preheating	90 to 150	<150
Dwelling	255 to 290	3 to 10

## Recommended Hand-Soldering Parameters

Item	Condition
Temp. of Solder Head	350 °C (max.)
Soldering Time	4 seconds (max.)

## Glossary

Item	Description
$V_N$	<b>Nominal Varistor Voltage</b> Voltage, at specified D.C. current used as a reference point in the component characteristics. — (GB 18802.331) — (IEC 61051-1)
$I_L$	<b>Leakage Current</b> Measuring at 75% of varistor voltage. — (GB/T 10193) — (IEC 61051-1)
UCT	<b>Upper Category Temp.</b> Max. ambient temp. for which a varistor has been designed to operate continuously. — (GB/T 10193) — (IEC 61051-1)
LCT	<b>Lower Category Temp.</b> Minimum ambient temp. at which a varistor has been designed to operate continuously. — (GB/T 10193) — (IEC 61051-1)
Max. Peak Current	<b>Max. Peak Current</b> Max. current per pulse, which may be passed by a varistor at an ambient temp. of 25 °C, for a given number of pulses. — (GB/T 10193) — (IEC 61051-1)
$V_C$	<b>Clamping Voltage</b> Peak voltage developed across the varistor terminations under standard atmospheric conditions, when passing an 8/20 $\mu$ s class current pulse. — (GB 18802.331) — (IEC 61051-1)
Voltage Proof	<b>Voltage Proof</b> Max. peak voltage, which may be applied under continuous operating conditions between the varistor terminations and any conducting mounting surface (Applicable only to insulated varistors). — (GB/T 10193) — (IEC 61051-1)
$C_V$	<b>Capacitance</b> Capacitance across the MOV measured at a specified frequency and voltage. — (GB 18802.331) — (IEC 61051-1)
$V_{ac}$	<b>Max. Continuous a.c. Voltage</b> Max. a.c. r.m.s. voltage of a substantially sinusoidal waveform (less than 5% total harmonic distortion) which can be applied to the component under continuous operating conditions at 25 °C. — (GB/T 10193) — (IEC 61051-1)
$V_{dc}$	<b>Max. Continuous d.c. Voltage</b> Max. d.c. voltage (with less than 5% ripple) which can be applied to the component under continuous operating conditions at an ambient temp. of 25 °C. — (GB/T 10193) — (IEC 61051-1)
$I_{max}$	<b>Max. Discharge Current</b> Crest value of a current through the SPD having an 8/20 $\mu$ s waveshape and magnitude according to the manufacturers specification. $I_{max}$ is equal to or greater than $I_n$ . — (GB 18802.1) — (IEC 61643-11)



# ATTENTION

## Usage

1. Varistor must operated in the specified ambient temp.
2. Do not clean the varistor with strong polar solvent such as ketone, esters, benzene and halogenated hydrocarbon.
3. Please do not apply severe vibration, shock or pressure to MOV.
4. Please fix lead wires when bending or cutting. The distance between the bending point and the sealing of MOV shall be greater than 2 mm.

## Replacement

If varistor is visually damaged, please replace it.

## Storage

1. Storage Temp. Range: (-40 to +125) °C.
2. Relative Humidity : ≤75% RH.
3. Altitude: <2000 m.
4. Do not store the MOV at the high temp., high humidity or corrosive gas environment, to avoid influencing the solder-ability of the lead wires, the product shall be used up within 1 year after receiving the goods.

## Environmental Conditions

1. Varistor should neither be exposed to the open air, nor direct sunshine.
2. Varistor should avoid rain, water vapor or other condition of high temp. and high humidity.
3. Varistor should avoid sand dust, salt spray, or other harmful gases.

## Max. Typical Capacitance of Varistor

The typical capacitance of varistor is listed in the specifications. Designers may refer to it when designing MOV in high frequency circuit.

**Metal Oxide Varistor (MOV) Feature & Model List Overview**

Nominal Operating Voltage $U_n$ (V)												Page		Model	Maximum Continuous Operating Voltage $U_n$ (V)
												AC	DC		
480V	500V	○	○	○	○	○	○	SFV10D122K(T)	SFV14D122K(T)	SFV20D122K(T)	SFV25D122K(T)	SFV53D122K	750	990	Maximum Continuous Operating Voltage $U_n$ (V)
		○	○	○	○	○	○	SFV10D112K(T)	SFV14D112K(T)	SFV20D112K(T)	SFV25D112K(T)	SFV53D112K	680	895	
415V	○	○	○	○	○	○	SFV10D102K(T)	SFV14D102K(T)	SFV20D102K(T)	SFV25D102K(T)	SFV53D102K	625	825		
380V	250V	○	○	SFV7D821K(T)	○	○	SFV10D911K(T)	SFV14D911K(T)	SFV20D911K(T)	SFV25D911K(T)	SFV53D911K	550	745		
		○	○	SFV7D751K(T)	○	○	SFV10D821K(T)	SFV14D821K(T)	SFV20D821K(T)	SFV25D821K(T)	SFV53D821K	510	670		
100V	240V	○	○	SFV7D751K(T)	○	○	SFV10D751K(T)	SFV14D751K(T)	SFV20D751K(T)	SFV25D751K(T)	SFV53D751K	460	615		
		○	○	SFV7D681K(T)	○	○	SFV10D681K(T)	SFV14D681K(T)	SFV20D681K(T)	SFV25D681K(T)	SFV53D681K	420	560		
240V	125V	○	○	SFV7D621K(T)	○	○	SFV10D621K(T)	SFV14D621K(T)	SFV20D621K(T)	SFV25D621K(T)	SFV53D621K	385	505		
		○	○	SFV7D561K(T)	○	○	SFV10D561K(T)	SFV14D561K(T)	SFV20D561K(T)	SFV25D561K(T)	SFV53D561K	350	460		
100V	120V	○	○	SFV7D511K(T)	○	○	SFV10D511K(T)	SFV14D511K(T)	SFV20D511K(T)	SFV25D511K(T)	SFV53D511K	320	415		
		○	○	SFV7D471K(T)	○	○	SFV10D471K(T)	SFV14D471K(T)	SFV20D471K(T)	SFV25D471K(T)	SFV53D471K	300	385		
220V	100V	○	○	SFV7D431K(T)	○	○	SFV10D431K(T)	SFV14D431K(T)	SFV20D431K(T)	SFV25D431K(T)	SFV53D431K	275	350		
		○	○	SFV7D391K(T)	○	○	SFV10D391K(T)	SFV14D391K(T)	SFV20D391K(T)	SFV25D391K(T)	SFV53D391K	250	320		
100V	48V	○	○	SFV7D361K(T)	○	○	SFV10D361K(T)	SFV14D361K(T)	SFV20D361K(T)	SFV25D361K(T)	SFV53D361K	230	300		
		○	○	SFV7D331K(T)	○	○	SFV10D331K(T)	SFV14D331K(T)	SFV20D331K(T)	SFV25D331K(T)	SFV53D331K	210	275		
120V	24V	○	○	SFV7D301K(T)	○	○	SFV10D301K(T)	SFV14D301K(T)	SFV20D301K(T)	SFV25D301K(T)	SFV53D301K	190	250		
		○	○	SFV7D271K(T)	○	○	SFV10D271K(T)	SFV14D271K(T)	SFV20D271K(T)	SFV25D271K(T)	SFV53D271K	175	225		
100V	12V	○	○	SFV7D241K(T)	○	○	SFV10D241K(T)	SFV14D241K(T)	SFV20D241K(T)	SFV25D241K(T)	SFV53D241K	150	200		
		○	○	SFV7D221K(T)	○	○	SFV10D221K(T)	SFV14D221K(T)	SFV20D221K(T)	SFV25D221K(T)	SFV53D221K	140	180		
48V	12V	○	○	SFV7D201K(T)	○	○	SFV10D201K(T)	SFV14D201K(T)	SFV20D201K(T)	SFV25D201K(T)	SFV53D201K	130	170		
		○	○	SFV7D181K(T)	○	○	SFV10D181K(T)	SFV14D181K(T)	SFV20D181K(T)	SFV25D181K(T)	SFV53D181K	115	150		
24V	12V	○	○	SFV7D151K(T)	○	○	SFV10D151K(T)	SFV14D151K(T)	SFV20D151K(T)	SFV25D151K(T)	SFV53D151K	95	125		
		○	○	SFV7D121K(T)	○	○	SFV10D121K(T)	SFV14D121K(T)	SFV20D121K(T)	SFV25D121K(T)	SFV53D121K	75	100		
12V	12V	○	○	SFV7D101K(T)	○	○	SFV10D101K(T)	SFV14D101K(T)	SFV20D101K(T)	SFV25D101K(T)	SFV53D101K	60	85		
		○	○	SFV7D820K(T)	○	○	SFV10D820K(T)	SFV14D820K(T)	SFV20D820K(T)	SFV25D820K(T)	SFV53D820K	50	65		
AC	DC	SFV7D680K(T)	SFV10D680K(T)	○	SFV14D680K(T)	SFV20D680K(T)	○	SFV25D680K(T)	○	○	○	40	56		
		SFV7D560K(T)	SFV10D560K(T)	○	SFV14D560K(T)	SFV20D560K(T)	○	SFV25D560K(T)	○	○	○	35	45		
12V	12V	SFV7D470K(T)	SFV10D470K(T)	○	SFV14D470K(T)	SFV20D470K(T)	○	SFV25D470K(T)	○	○	○	30	38		
		SFV7D390K(T)	SFV10D390K(T)	○	SFV14D390K(T)	SFV20D390K(T)	○	SFV25D390K(T)	○	○	○	25	31		
12V	12V	SFV7D330K(T)	SFV10D330K(T)	○	SFV14D330K(T)	SFV20D330K(T)	○	SFV25D330K(T)	○	○	○	20	26		
		SFV7D270K(T)	SFV10D270K(T)	○	SFV14D270K(T)	SFV20D270K(T)	○	SFV25D270K(T)	○	○	○	17	22		
12V	12V	SFV7D220K(T)	SFV10D220K(T)	○	SFV14D220K(T)	SFV20D220K(T)	○	SFV25D220K(T)	○	○	○	14	18		

**Metal Oxide Varistor (MOV) Feature & Model List Overview**

Nominal Operating Voltage $U_n$ (V)						Page		Model	Maximum Continuous Operating Voltage $U_n$ (V)	
		1.75	3.5	6	10	20	AC		DC	
480V	500V	○	SFV10D122KM	SFV14D122KM	SFV20D122KM	SFV25D122KM	750	990	Maximum Continuous Operating Voltage $U_n$ (V)	
		○	SFV10D112KM	SFV14D112KM	SFV20D112KM	SFV25D112KM	680	895		
		○	SFV10D102KM	SFV14D102KM	SFV20D102KM	SFV25D102KM	625	825		
		○	SFV10D911KM	SFV14D911KM	SFV20D911KM	SFV25D911KM	550	745		
380V	500V	SFV7D821KM	SFV10D821KM	SFV14D821KM	SFV20D821KM	SFV25D821KM	510	670		
		SFV7D751KM	SFV10D751KM	SFV14D751KM	SFV20D751KM	SFV25D751KM	460	615		
100V	240V	SFV7D681KM	SFV10D681KM	SFV14D681KM	SFV20D681KM	SFV25D681KM	420	560		
		SFV7D621KM	SFV10D621KM	SFV14D621KM	SFV20D621KM	SFV25D621KM	385	505		
240V	240V	SFV7D561KM	SFV10D561KM	SFV14D561KM	SFV20D561KM	SFV25D561KM	350	460		
		SFV7D511KM	SFV10D511KM	SFV14D511KM	SFV20D511KM	SFV25D511KM	320	415		
100V	250V	SFV7D471KM	SFV10D471KM	SFV14D471KM	SFV20D471KM	SFV25D471KM	300	385		
		SFV7D431KM	SFV10D431KM	SFV14D431KM	SFV20D431KM	SFV25D431KM	275	350		
100V	250V	SFV7D391KM	SFV10D391KM	SFV14D391KM	SFV20D391KM	SFV25D391KM	250	320		
		SFV7D361KM	SFV10D361KM	SFV14D361KM	SFV20D361KM	SFV25D361KM	230	300		
120V	250V	SFV7D331KM	SFV10D331KM	SFV14D331KM	SFV20D331KM	SFV25D331KM	210	275		
		SFV7D301KM	SFV10D301KM	SFV14D301KM	SFV20D301KM	SFV25D301KM	190	250		
100V	125V	SFV7D271KM	SFV10D271KM	SFV14D271KM	SFV20D271KM	SFV25D271KM	175	225		
		SFV7D241KM	SFV10D241KM	SFV14D241KM	SFV20D241KM	SFV25D241KM	150	200		
		SFV7D221KM	SFV10D221KM	SFV14D221KM	SFV20D221KM	SFV25D221KM	140	180		
		SFV7D201KM	SFV10D201KM	SFV14D201KM	SFV20D201KM	SFV25D201KM	130	170		
48V	125V	SFV7D181KM	SFV10D181KM	SFV14D181KM	SFV20D181KM	SFV25D181KM	115	150		
		SFV7D151KM	SFV10D151KM	SFV14D151KM	SFV20D151KM	SFV25D151KM	95	125		
		SFV7D121KM	SFV10D121KM	SFV14D121KM	SFV20D121KM	SFV25D121KM	75	100		
		SFV7D101KM	SFV10D101KM	SFV14D101KM	SFV20D101KM	SFV25D101KM	60	85		
24V	12V	SFV7D820KM	SFV10D820KM	SFV14D820KM	SFV20D820KM	SFV25D820KM	50	65		
		○	○	SFV25D680KM	○	○	40	56		
12V	12V	○	○	SFV25D560KM	○	○	35	45		
		○	○	SFV25D470KM	○	○	30	38		
12V	12V	○	○	○	○	○	25	31		
		○	○	○	○	○	20	26		
AC	DC	○	○	○	○	○	17	22		
		○	○	○	○	○	14	18		

Maximum Peak Current (8/20  $\mu$ s) (kA)

**Metal Oxide Varistor (MOV) Feature & Model List Overview**

Nominal Operating Voltage $U_n$ (V)		Model											Page	
		Maximum Continuous Operating Voltage $U_n$ (V)											AC	DC
480V	500V	○	○	○	○	○	○	SFV20S122K	○	SFV25S122K	SFV34S122K	750	990	
		○	○	○	○	○	○	SFV20S112K	○	SFV25S112K	SFV34S112K	680	895	
415V	500V	○	○	○	○	○	○	SFV20S102K	○	SFV25S102K	SFV34S102K	625	825	
		○	○	○	○	○	○	SFV20S911K	○	SFV25S911K	SFV34S911K	550	745	
380V	500V	○	○	SFV10S821K	○	○	SFV15S821K	○	SFV20S821K	○	SFV25S821K	SFV34S821K	510	670
		○	○	SFV10S751K	○	○	SFV15S751K	○	SFV20S751K	○	SFV25S751K	SFV34S751K	460	615
100V	-	○	○	SFV10S681K	○	○	SFV15S681K	SFV20S681K	○	SFV25S681K	SFV34S681K	420	560	
		○	○	SFV10S621K	○	○	SFV15S621K	SFV20S621K	○	SFV25S621K	SFV34S621K	385	505	
240V	-	○	○	SFV10S561K	○	○	SFV15S561K	SFV20S561K	○	SFV25S561K	SFV34S561K	350	460	
		○	○	SFV10S511K	○	○	SFV15S511K	SFV20S511K	○	SFV25S511K	SFV34S511K	320	415	
100V	250V	○	○	SFV10S471K	○	○	SFV15S471K	SFV20S471K	○	SFV25S471K	SFV34S471K	300	385	
		○	○	SFV10S431K	○	○	SFV15S431K	SFV20S431K	○	SFV25S431K	SFV34S431K	275	350	
220V	250V	○	○	SFV10S391K	○	○	SFV15S391K	SFV20S391K	○	SFV25S391K	SFV34S391K	250	320	
		○	○	SFV10S361K	○	○	SFV15S361K	SFV20S361K	○	SFV25S361K	SFV34S361K	230	300	
100V	-	○	○	SFV10S331K	○	○	SFV15S331K	SFV20S331K	○	SFV25S331K	SFV34S331K	210	275	
		○	○	SFV10S301K	○	○	SFV15S301K	SFV20S301K	○	SFV25S301K	SFV34S301K	190	250	
120V	-	○	○	SFV10S271K	○	○	SFV15S271K	SFV20S271K	○	SFV25S271K	SFV34S271K	175	225	
		○	○	SFV10S241K	○	○	SFV15S241K	SFV20S241K	○	SFV25S241K	SFV34S241K	150	200	
100V	125V	○	○	SFV10S221K	○	○	SFV15S221K	SFV20S221K	○	SFV25S221K	SFV34S221K	140	180	
		○	○	SFV10S201K	○	○	SFV15S201K	SFV20S201K	○	SFV25S201K	SFV34S201K	130	170	
48V	-	○	○	SFV10S181K	○	○	SFV15S181K	SFV20S181K	○	SFV25S181K	SFV34S181K	115	150	
		○	○	SFV10S151K	○	○	SFV15S151K	SFV20S151K	○	SFV25S151K	SFV34S151K	95	125	
24V	-	○	SFV10S121K	○	○	○	SFV15S121K	SFV20S121K	○	SFV25S121K	SFV34S121K	75	100	
		○	SFV10S101K	○	○	○	SFV15S101K	SFV20S101K	○	SFV25S101K	SFV34S101K	60	85	
12V	-	○	SFV10S820K	○	○	○	SFV15S820K	SFV20S820K	○	SFV25S820K	SFV34S820K	50	65	
		SFV10S680K	SFV15S680K	SFV20S680K	○	○	SFV25S680K	○	SFV34S680K	○	○	40	56	
12V	-	SFV10S560K	SFV15S560K	SFV20S560K	○	○	SFV25S560K	○	SFV34S560K	○	○	35	45	
		SFV10S470K	SFV15S470K	SFV20S470K	○	SFV25S470K	○	SFV34S470K	○	○	○	30	38	
12V	-	SFV10S390K	SFV15S390K SFV20S390K	○	○	SFV25S390K	○	○	○	○	○	25	31	
		SFV10S330K	SFV15S330K SFV20S330K	○	○	SFV25S330K	○	○	○	○	○	20	26	
12V	-	SFV10S270K	SFV15S270K SFV20S270K	○	SFV25S270K	○	○	○	○	○	○	17	22	
		SFV10S220K	SFV15S220K SFV20S220K SFV25S220K	○	○	○	○	○	○	○	○	14	18	
AC	DC	2	3	5	6	8	10	15	20	25	40	AC	DC	